

## KAKKU HEAVY DUTY THRUSTOR BRAKES SERIES KBT

### SPECIAL FEATURES

- Well proven performance and hence reliability is ensured.
- Ease of adjustment of torque quickly, by just turning the adjustment nut.
- Accurate manufacturing and strict adherence to engineering standards for longer working life.
- All parts are easily accessible and hence ensures quick maintenance.
- Quick adjustment of both the shoes together by just one adjustment bolt to maintain uniform shoe gap.

### SALIENT FEATURES SIMPLICITY

KAKKU Brakes series KBT are robust in construction and simple in design having minimum number of parts and thus reducing maintenance problems and down time.

### RELIABLE BRAKING ACTION

The design of KAKKU brakes ensures efficient transmission of braking force. Also the braking action is spread evenly over both the shoes providing maximum stopping power with minimum wear of shoe linings. Because of the large bearing area and close tolerances, minimum wear of supporting pins is ensured.

### LINING

Shoe linings are made from asbestos based woven material, which has a high co-efficient of friction and low rate of wear. The linings are normally riveted to the shoe.

### SHOE ADJUSTMENT

Uniform receding of both the shoes can be adjusted by just turning one shoe adjustor bolt, provided on the lever arm Adjustment can be locked with the help of check nut.

### SHOE POSITIONING

The brakes are provided with shoe positioners under the brake shoe to rigidly secure the brake shoe and prevent them from tilting and riding the drum when brakes are released.

### TORQUE SETTING

Braking torque can be set and maintained conveniently. Each position of setting can be locked to prevent any disturbance due to vibration.

### FAIL SAFE DESIGN

KAKKU Thrustor brakes series KBT are electrically released and spring set. Release of the brake shoes is effected by energising the three phase thrustor which overcomes the spring force and the shoes are moved away from the drum by the lever/ arm linkages system. On De-energising the three phase thrustor, the shoes are pressed against the drum, thus setting the brake. This makes the brake fail safe in the event of power failure.

### DIMENSIONS

For dimensional details, please refer to dimensional data sheets.

### TECHNICAL DATA

Torque Characteristics	:	See relevant dimensional sheets
Class of insulation of Thrustor	:	Class 'F'
Insulation Voltage	:	660V
Operating Voltage	:	415V, 3 Phase 50 Hz AC
Recommended Oil	:	As per IS 335/1972 (Transformer Oil)

### Power Consumption

Thrustor Type	Capacity	Current Drawn (Amps)
KT-018	18Kg	0.25
KT-034	34Kg	0.45
KT-046	46Kg	0.50
KT-068	68Kg	0.55
KT-080	80Kg	0.60
KT-115	115Kg	0.75
KTM-025	25Kg	0.25

Even though the thrustors are class 'F' insulated, the temperature rise is within the limits of class 'B'. Therefore good life of insulation is ensured. The thrustors are tested as per relevant IPSS.

### SELECTION OF BRAKE SIZE

For most applications, the brake torque must be equal to or greater than motor full load torque as referred to the drum/ wheel shaft.

$$\text{Thus, torque in Kg m} = \frac{974 \times \text{KW}}{\text{rpm}}$$

Where,

$$\begin{aligned} \text{KW} &= \text{Motor Output} \\ \text{rpm} &= \text{Revolution per minute} \end{aligned}$$

With torque requirements known and the type and the duty cycle established, the brake is selected accordingly from the selection table. For certain special applications e.g. crane hoist and other overhauling loads, the brake should be capable of providing atleast 150% of motor torque.

### OPTIONAL EXTRAS

- Special epoxy paint to withstand corrosive atmosphere.
- Shoe bolted linings.

### ORDERING INFORMATION

- Give KAKKU type No.
- Specify optional extras if any.

*Product improvement is a continuous process at KAKKU. Hence data given in this catalogue is subject to revision without notice.*



Symbol Of Reliability

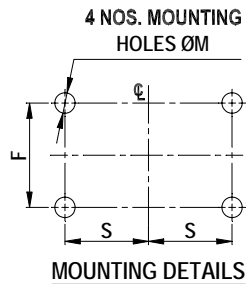
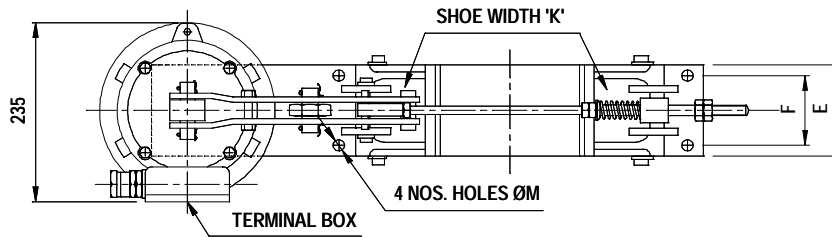
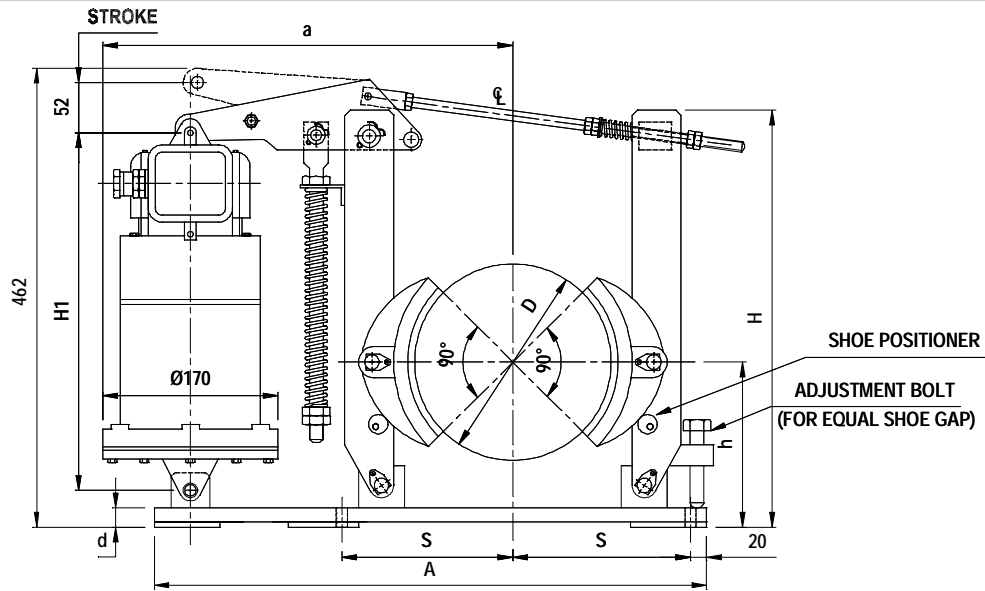

Brake Type	Drum Dia 'D' (mm)	Braking Torque (Kg. M)	Thrustor Type	Dimensions in (mm)											Wt. in Kgs. (Approx.)
				A	S	E	F	H	H1	h	ØM	K	a	d	
KBT-100/18	100	6	KT-018	430	110	70	40	432	349	100	11	58	350	16	25
KBT-150/18	150	9	KT-018	504	155	80	50	432	349	140	14	70	380	16	27
KBT-160/18	160	9	KT-018	514	155	80	50	432	349	140	14	70	390	16	27
KBT-180/18	180	16	KT-018	550	175	85	55	432	349	165	14	80	410	16	30
KBT-200/18	200	20	KT-018	570	185	90	60	432	349	170	14	90	420	16	31
KBT-250/18 A	250	28	KT-018	638	220	100	70	432	349	200	14	100	450	16	37
KBT-250/18 B	250	35	KT-018	720	220	100	70	432	349	200	14	100	533	16	37
KBT-300/18	300	42	KT-018	780	250	120	80	525	349	240	18	125	565	18	48



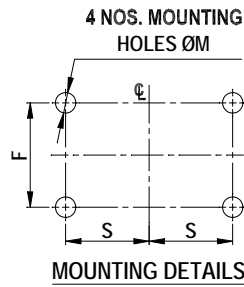
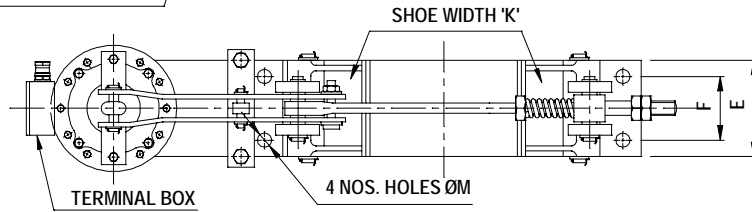
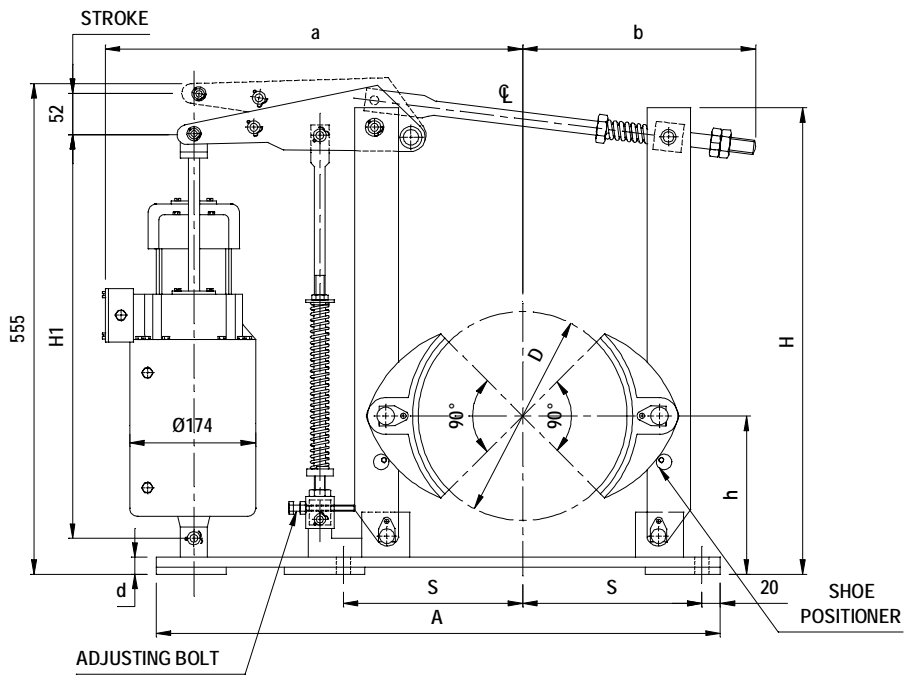

Brake Type	Drum Dia 'D' (mm)	Braking Torque (Kg M)	Thruster Type	Dimensions (m m)								
				A	S	E	F	H	H1	h	ØM	K
KBT-200/34	200	32	KT-034	570	185	90	60	525	444	170	14	90
KBT-250/34	250	42	KT-034	638	220	100	70	525	444	200	14	100
KBT-300/34	300	62	KT-034	780	250	120	80	525	444	240	18	125

Brake Type	Dimensions in (mm)				Wt. in Kgs. (Approx.)
	a	b	d		
KBT-200/34	475	215	16		48
KBT-250/34	505	245	16		55
KBT-300/34	605	290	18		70



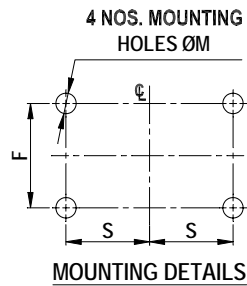
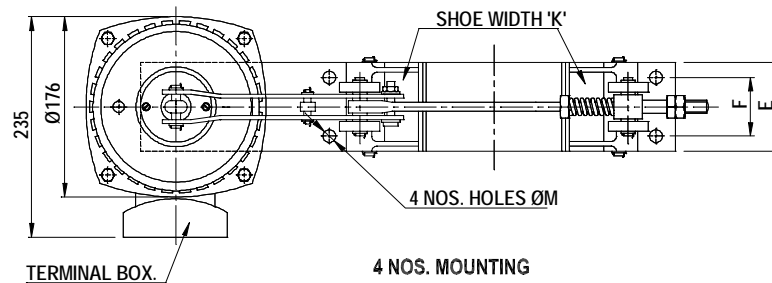
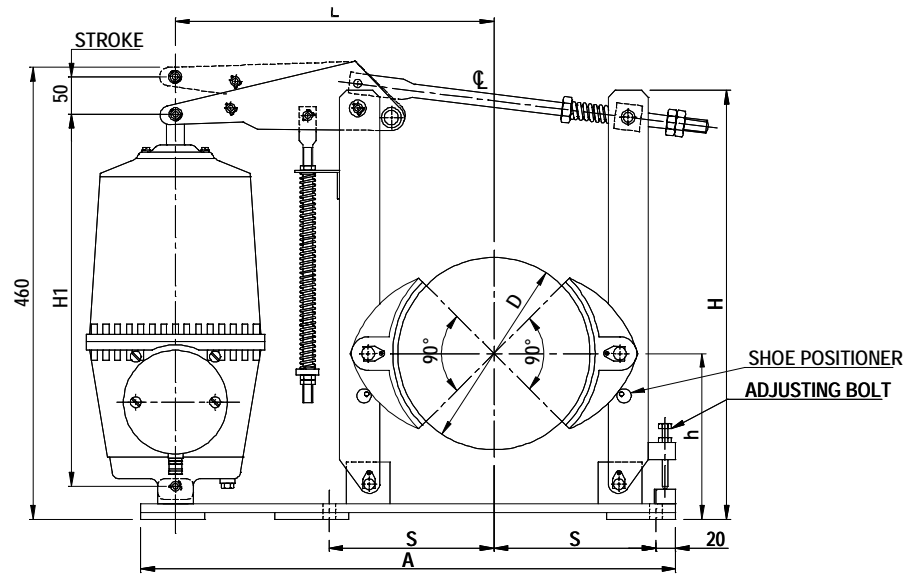

Brake Type	Drum Dia D (mm)	Braking Torque (Kg M)	Thrustor Type *	Dimensions (m m)										Wt. in Kgs. (Approx.)
				A	S	E	F	H	H1	h	ØM	K	L	
KBT-100/25	100	7.5	KTM-025	430	110	70	40	432	355	100	11	58	348	37
KBT-150/25	150	11	KTM-025	500	155	80	50	432	355	140	14	70	373	40
KBT-160/25	160	11	KTM-025	510	155	80	50	432	355	140	14	70	383	40
KBT-200/25	200	25	KTM-025	570	185	90	60	432	355	170	14	90	413	44
KBT-250/25	250	28	KTM-025	638	220	100	70	432	355	200	14	100	428	48
KBT-300/25	300	45	KTM-025	780	250	120	80	525	355	240	18	125	568	66

\* TOTALLY SEALED, STEEL PLANT DUTY THRUSTOR.



Symbol Of Reliability

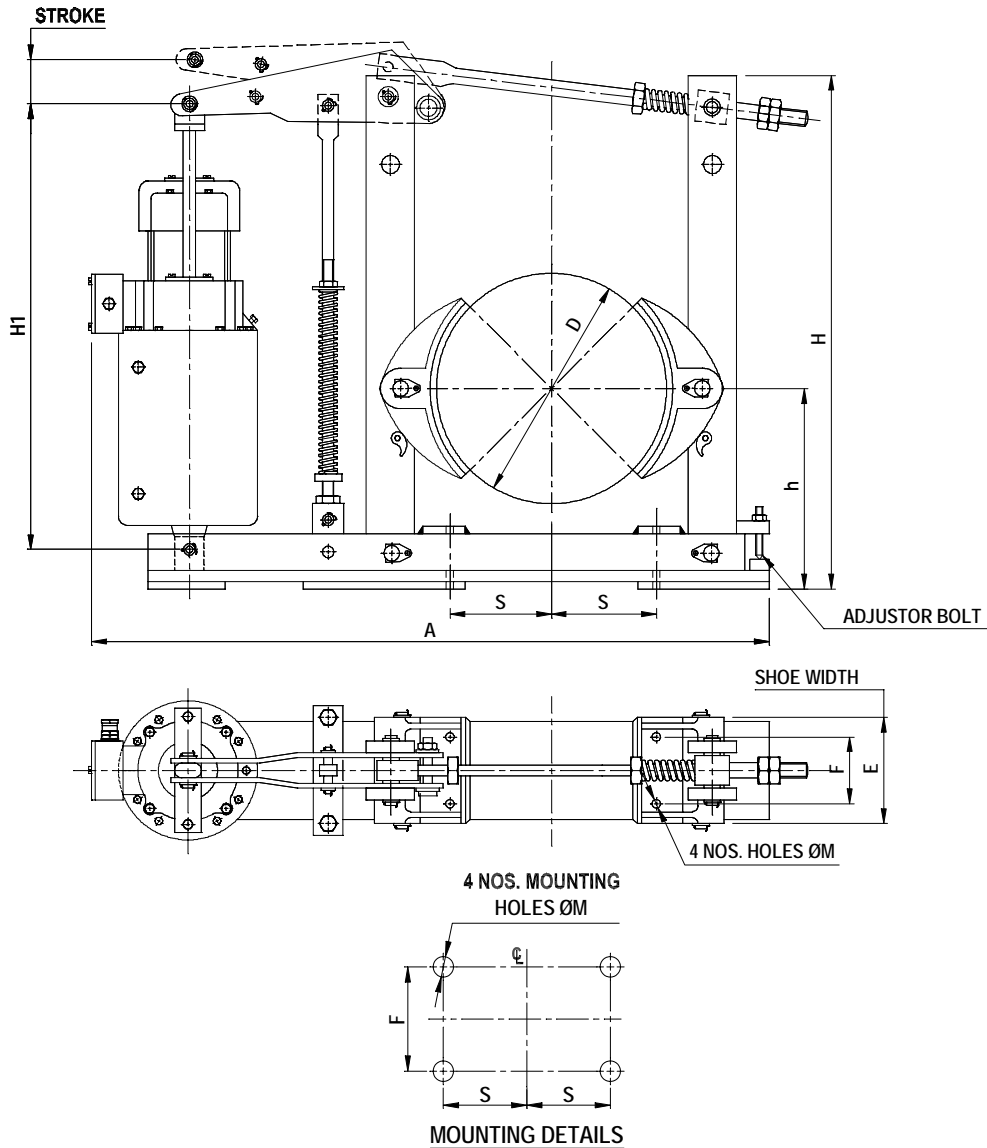

Brake Type	Drum Dia D (mm)	Braking Torque (Kg M)	Stroke (mm)	Thrustor Type	Dimensions (m m)								Wt. in Kgs. (Approx.)
					A	S	E	F	H	H1	h	ØM	
KBT-400/34	400	80	52	KT-34	1160	170	180	90	660	444	320	18	
KBT-400/46	400	110	52	KT-46	1160	170	180	90	660	444	320	18	
KBT-400/68	400	150	80	KT-68	1188	170	180	90	660	455	320	18	
KBT-400/80	400	150	80	KT-80	1195	170	180	90	660	455	320	18	
KBT-500/68	500	180	80	KT-68	1260	205	200	100	795	455	400	25	200
KBT-500/80	500	180	80	KT-80	1234	205	200	100	795	455	400	25	
KBT-500/115	500	250	80	KT-115	1260	205	200	100	795	508	400	25	
KBT-600/115	600	360	80	KT-115	1455	250	240	126	905	508	475	38	

**Electronic & Power Control Co.**

(AN ENTERPRISE OF KAKKU E & P CONTROL (P) LTD.)  
1, Industrial Estate, Bhilai 490 026,  
(Chhattisgarh) INDIA.



Symbol Of Reliability

Tel : 91-788-2382610, 2382297  
Fax : 91-788-2381797, 2321836  
E-mail : kakku\_bhilai@yahoo.com