

WEIGHT OPERATED HOIST LIMIT SWITCHES TYPE KWLS – 223

SPECIAL FEATURES

- Double break contacts with high quality silver alloy tips, having arc – retarding and anti welding properties.
- Provided with specially treated oil resistant rubber gasket to make the switch completely dust proof.
- Ease of maintenance.
- Reliability of performance.
- Resists extreme shocks & vibratory conditions.

Housing	:	Cast Aluminium housing with detachable steel over.
Protection	:	IP-55
Terminals	:	Suitable for conductor size 2.5mm ²
Contact sequence	:	1NO + 1NC (Snap Action)
Rated duty	:	2500 operations per hour
Electrical & mechanical life	:	10 million operations.
Rated insulation voltage	:	500V AC/ DC
Rated thermal current	:	10A

APPLICATIONS

KAKKU Limit Switch Type KWLS – 223 is used as over hoist limit switch in electrically operated cranes/ hoist.

OPTIONAL EXTRAS

- Enclosure upto IP-65
- Epoxy paint for special applications.
- Set of accessories comprising of snatch block, 2Mtrs. wire rope and rope fastening arrangement.

TECHNICAL DATA

Ambient temperature	:	-10 to +60°C
Mounting	:	Surface

TYPE KWLS – 223
Dimensions (mm)

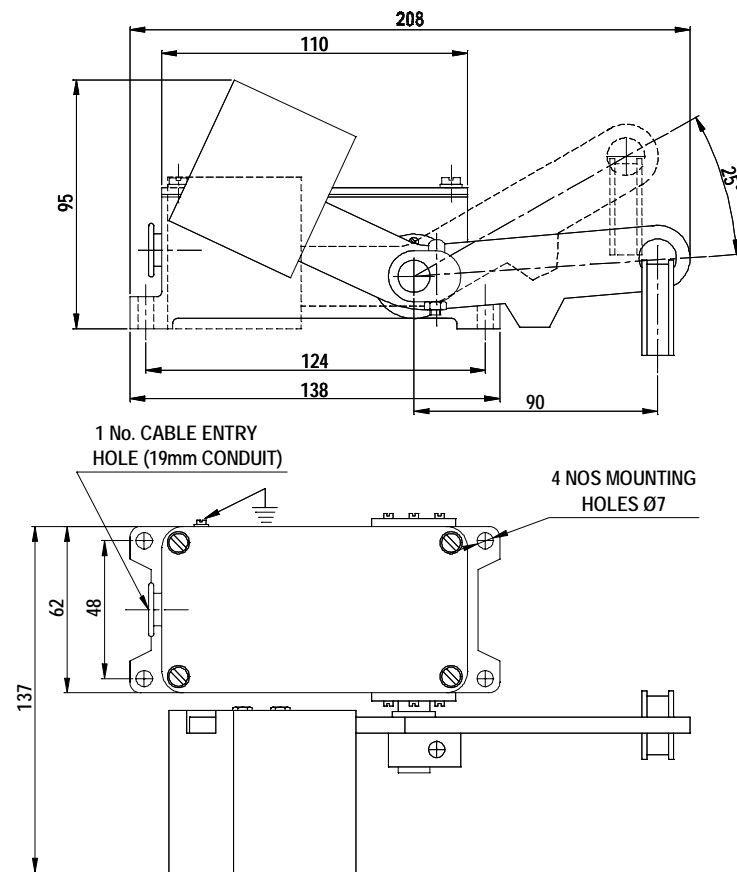

Fig. 1 WEIGHT OPERATED HOIST LIMIT SWITCH

RATED OPERATIONAL CURRENT					
AC upto 40 to 60 Hz			DC		
V	AC-12	AC-15	V	DC-12	DC-13
24	10	10	24	10	10
125	10	10	48	6	4
230	10	6	110	4	1
400	10	4	220	1	0.4
500	10	3	440	0.5	0.2

Product improvement is a continuous process at KAKKU. Hence data given in this catalogue is subject to revision without notice.

Electronic & Power Control Co.

(AN ENTERPRISE OF KAKKU E & P CONTROL (P) LTD.)
1, Industrial Estate, Bhilai 490 026,
(Chhattisgarh) INDIA.



Symbol Of Reliability

Tel : 91-788-2382610, 2382297
Fax : 91-788-2381797, 2321836
E-mail : kakku_bhilai@yahoo.com