

ROLLER LEVER OPERATED LIMIT SWITCHES

SERIES KL - 040

SPECIAL FEATURES

- Bi-directional self reset operation with 2NC contacts, one contact opening in either direction of lever operation.
- Double break contacts with high quality silver alloy tips, having arc-retarding and anti-welding properties.
- Provided with specially treated oil resistant rubber gasket to make the switch completely dust proof.
- Reliability of performance.
- Resists extreme shocks & vibratory conditions.
- Liberal over travel.

APPLICATIONS

KAKKU Limit Switch Series KL-040 are designed particularly for EOT Cranes/ Hoist for use in CT/ LT applications. Besides this, these limit switches can also be used for Transfer cars, Elevators etc. for slowing down/ stopping the drive at the end limits of its travel.

CONSTRUCTION & OPERATION

The Limit Switch is provided with two fixed contact blocks and a moving contact block. The moving contact block is assembled between two fixed contact blocks such that 2NC contact are obtained with the help of bridge type moving contacts.

When the operating lever is actuate, one NC contact opens in either direction of the lever operation because of the action of spring force on the moving contact block. The switch operates with normal (slow) action and is self reset type.

OPTIONAL EXTRAS

- Special shape and size of lever
- Suitable base plate at the bottom to match any mounting dimensions (furnish drawing).
- Epoxy paint for special applications.

TECHNICAL DATA

Ambient Temperature	:	Upto 60°C
Mounting	:	Surface
Housing	:	Cast Aluminium. with detachable cover.
Protection	:	IP-65
Terminals	:	Suitable for conductor size 2.5mm ²
Contacts	:	2NC
Rated Voltage	:	500V AC
Rated Current	:	10A (Continuous)
Maximum frequency of operation	:	600 cycles/ hour
Travel to trip (deg.)	:	10 (±2)
Total travel (deg.)	:	70
Recommended travel (deg.):	:	25 to 35

SERIES KL - 040
Dimensions (mm)

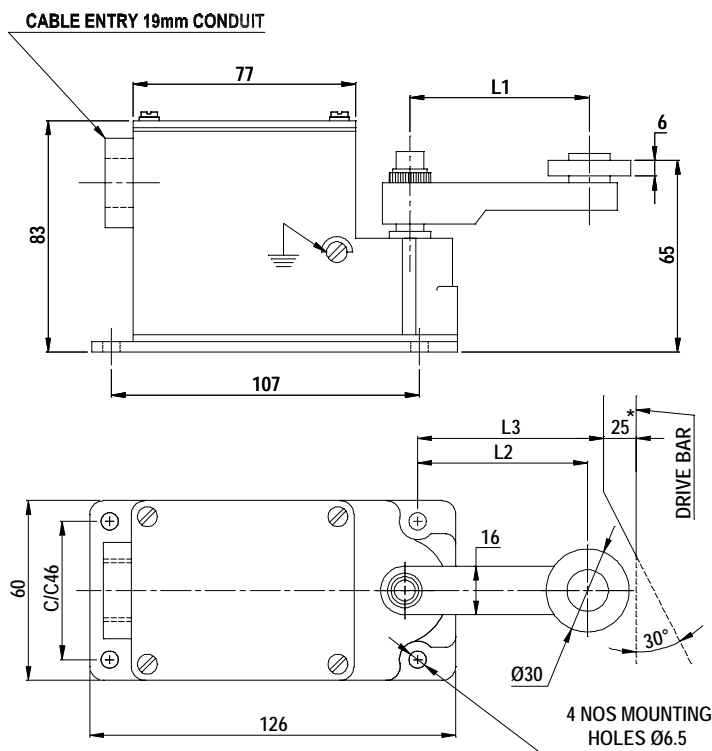

Fig. 1 ROLLER LEVER OPERATED LIMIT SWITCHES

Type	L1	L2	L3	Force to Trip (Kgs.)
KL - 041	65	60	63	0.90
KL - 042	38	33	36	1.50

* Min Dimensions

Product improvement is a continuous process at KAKKU. Hence data given in this catalogue is subject to revision without notice.

Electronic & Power Control Co.

(AN ENTERPRISE OF KAKKU E & P CONTROL (P) LTD.)
1, Industrial Estate, Bhilai 490 026,
(Chhattisgarh) INDIA.



Symbol Of Reliability

Tel : 91-788-2382610, 2382297
Fax : 91-788-2381797, 2321836
E-mail : kakku_bhilai@yahoo.com