

KAKKU HEAVY DUTY BELT SWAY SWITCHES

SERIES KCB

SPECIAL FEATURES

- Double break contacts with high quality Silver Alloy contact tips.
- Provided with specially treated oil resistant rubber gaskets at all the joints in the switch to make it completely dust proof.
- Splash proof design and can be installed in open or exposed to heavy rain without any special protection.
- Resists extreme shock and vibratory conditions.
- Ease of maintenance, reliability of performance, ensuring longer life.

APPLICATION

KAKKU Heavy Duty Belt Sway switches series KCB are designed for protection of belt conveyors from damage due to excessive swaying the switches are mounted at intervals on both sides of conveyor belts. When the belt sways beyond the permissible limits, the edge of the belt pushes the operating lever of the switch to actuate its contacts for stopping the conveyor.

CONSTRUCTION

The switch has a robust Cast Iron/ Cast Al. contact unit and a steel shaft carrying versatile moulded cam. The contact unit has spring loaded double break contacts. The operating lever is directly fitted on the shaft and is self re-set type. The switches are provided with 'break before make' contacts.

TECHINCAL DATA

Ambient Temperature : 55°C.
Mounting Arrangement : Surface mounting

Housing : Cast Iron/ Cast Aluminium housing and detachable cover.
Action : Self Reset
No. of Operating positions : 0 – 1
Enclosure category : As per IP-55 of IS : 2147 – 1962
Terminals : Suitable for conductor size 2.5mm²
Rating
1. Rated Voltage : Upto 500V AC
2. Continuous rated current : 10 Amps.

SELECTION CHART

Switch Type	Contact	Other Features
KCB – 210	1NO + 1NC	Without separate terminal box.
KCB – 220	2NO + 2NC	– Do –
KCB – 211	1NO + 1NC	With built in Terminal box having separate cover.
KCB – 221	2NO + 2NC	– Do –

OPTIONAL EXTRAS

- Better enclosure category.
- Epoxy paint for special applications.
- Single or double compression cable glands.
- Suitable base plate at bottom to match any mounting dimensions (furnish drawing)

ORDERING INFORMATION

- Give KAKKU type
- Contact opening & closing sequence for each of the contacts.
- Specify optional extras if any.

SERIES KCB
Dimensions (mm)

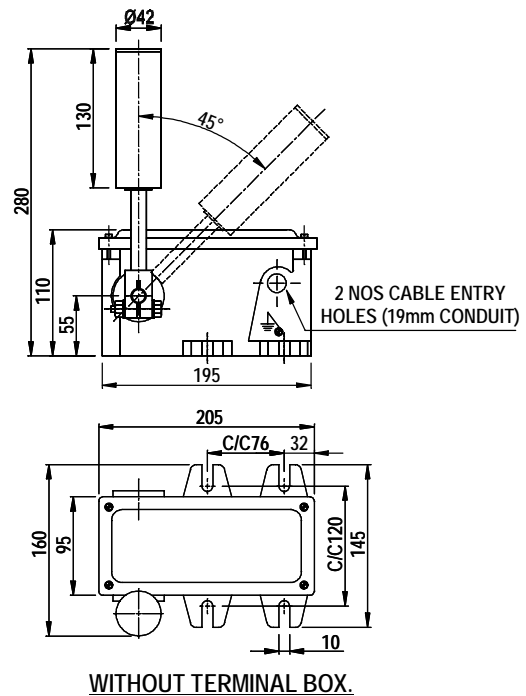
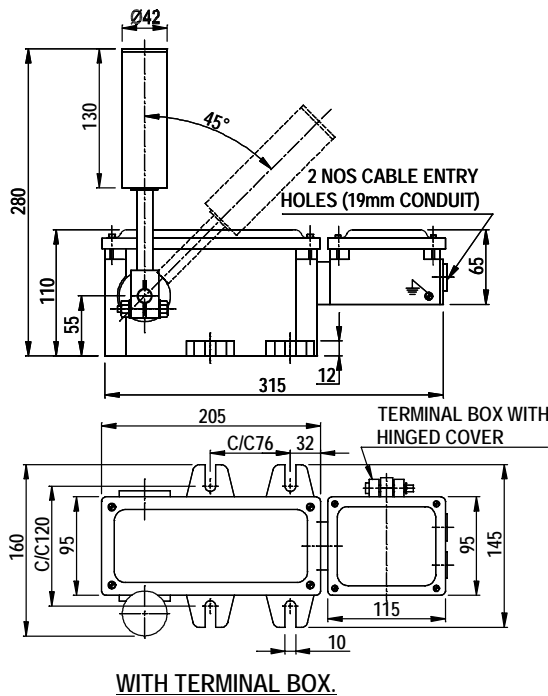

Product improvement is a continuous process at KAKKU. Hence data given in this catalogue is subject to revision without notice.

Electronic & Power Control Co.

(AN ENTERPRISE OF KAKKU E & P CONTROL (P) LTD.)

1, Industrial Estate, Bhilai 490 026,
(Chhattisgarh) INDIA.



Symbol Of Reliability

Tel : 91-788-2382610, 2382297

Fax : 91-788-2381797, 2321836

E-mail : kakku_bhilai@yahoo.com