

# KAKKU CONTINUOUS DUTY LOUD RINGING AC GONG BELLS

## TYPE KBL-74 & KDGB-79

### SPECIAL FEATURES

- Splash proof design and can be installed in open exposed to heavy rains coke & dust Laden atmosphere.
- Provided with specially designed electro-magnets to ensure steady supply of current to the coils thereby preventing its over heating even on continuous use.
- Special corrosion resistant gongs
- Suitable for continuous duty.
- Epoxy coated coils.
- Contact less and arc less operation.
- Mechanically robust and versatile & practically no maintenance required.
- Offers reliable performance and economy.

### APPLICATION

KAKKU Bells are recommended for use in EOT cranes, conveyor galleries, sub-stations, unguarded railway crossings, marine ships, theatres, schools banks etc. to give loud audio alarm signals. These are also suitable for dusty locations having good amount of current conducting dust or corrosive fumes as experienced in Steel Plants, Mines, fertilizer plants, Cement Plants, thermal Power Stations etc.

### TECHNICAL DATA

Ambient Temperature	: 55°C
Mounting Arrangement	: Wall mounting
Enclosure	: IP 65 of IS-2147-1962
Audibility	: As per selection chart.
Coil Voltage (A.C.)	: 12.24,48,110 230V A.C.
Duty	: Suitable for continuous operation .
Terminal block for connecting supply cable of size 1.5 mm <sup>2</sup>	

### DIMENSIONS

As per relevant figures shown in the dimensional data sheet.

### SELECTION CHART

KAKKU Type	Gong Dia (mm)	Design	Audibility (db)	Fig
KBL-74 (87)	87	Single Gong	85	1
KBL-74 (150)	150	Single Gong	97	1
KDGB-79	150	Double Gong	102	2

### OPTIONAL EXTRA

- Epoxy paint for special application.
- Single or double compression cable gland.

### ORDERING INFORMATION

- Give Kakku Type
- Optional Extra

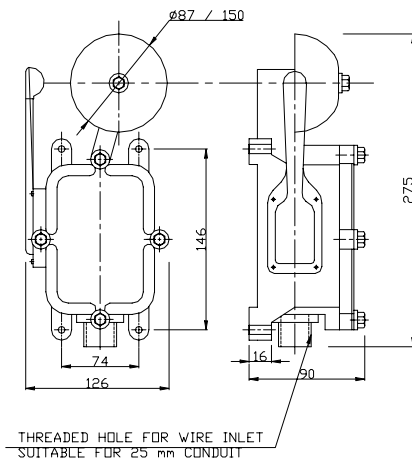

Fig 1

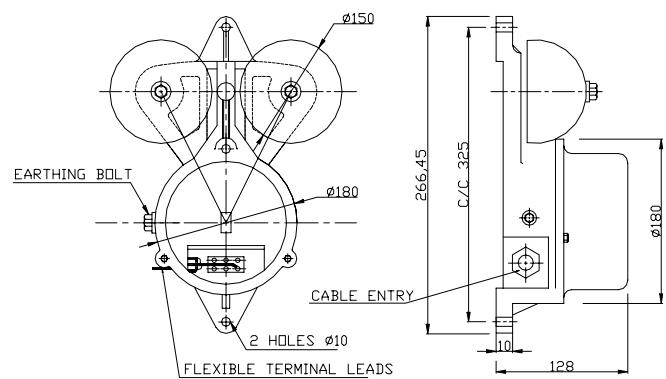

Fig.2

*Product improvement is a continuous process at KAKKU. Hence data given in this catalogue is subject to revision without notice.*

## Electronic & Power Control Co.

(AN ENTERPRISE OF KAKKU E & P CONTROL (P) LTD.)  
1, Industrial Estate, Bhilai 490 026,  
(Chhattisgarh) INDIA.



Symbol Of Reliability

Tel : 91-788-2382610, 2382297

Fax : 91-788-2381797, 2321836

E-mail : kakku\_bhilai@yahoo.com