

KAKKU FECHRAL WOUND TYPE GRID RESISTANCE BOXES

SERIES FGR – 1000

KAKKU fechral wound type grid resistors are designed for reliable service under heavy-duty operations. This design leaves no scope of current concentration as in the case of punched steel grids and therefore offers a very reliable performance for a wide range of industrial use. Such type of resistance grids also effectively resist vibration and shocks, normally encountered in mobile equipments.

SPECIAL FEATURES

- Each grid is of draw out type facilitating its quick replacement.
- The construction of resistance boxes is free from pressure joints between the grids.
- Negligible change in resistance value despite temperature variation due to low temperature co-efficient of fechral.
- Proven design with long life, needing practically no maintenance.
- Temperature rise of resistance boxes is limited to 375°C above the ambient temperature of 50°C as per NEMA and relevant IPSS.
- Provision of sufficient number of terminals for ease of adjustment of resistance.
- Standardised open type resistance boxes exactly replace Russian resistance boxes type НФ-IT, ЯС-3Т and ЯС-4Т.
- Available in open execution or with enclosure conforming to IP-11, 23, 33 as per IS-2147, 1962.

TYPES

RESISTANCE BOXES ARE BASICALLY OF TWO TYPES

1. Series FGR-1100

These are for low current values from 0.9A to 32 Amps. The grids are of Fechral wire (or constantan wire or tape) wound on special ceramic insulators mounted on a steel frame.

2. Series FGR-1200

These are for higher current ratings. The grids of these boxes are manufactured from edge wound Fechral strips mounted on special ceramic insulators supported on a steel frame.

However for applications such as rotor resistance of slipring induction motors, a combination of both the above types may also be supplied.

APPLICATION

Fechral grid resistance boxes series FGR-1000 are designed for use in power circuits with working voltage upto 500V and have varied applications such as:

- i. Starting and Dynamic braking resistors of Electric Locos.
- ii. Starters, Controllers, Regulators and Slip resistors for A.C slipring motors.
- iii. Starters for D.C Machines.
- iv. Loading resistors for generators and secondaries of transformers.
- v. Field discharge resistors of synchronous machines.
- vi. Crane duty resistors.
- vii. Neutral earthing resistors of substations.
- viii. A.C motor primary resistors starter.

CONSTRUCTION

Each grid is made from wire/ edge wound strips. The resistance coil is assembled with a set of insulators on a mounting steel frame such that there is no chance of the grid getting damaged due to vibrations. The ends of the edge wound coil of the grid is brazed with copper terminals from which tappings can be taken out.

The resistance boxes series FGR-1000 are available in open execution as per fig.2 & 3 and also with enclosure conforming to IP-23 as per fig.1. The open type fechral edge wound grid resistance boxes (type FGR-1211) have been standardised for many applications as per table 1. These are exact replacement of Russian type НФ- IT. Similarly wire wound grid resistance boxes (type FGR-1111) exactly replace Russian type ЯС-3Т, as per table-2. The enclosed type of resistance boxes are normally manufactured to suit the customer's specific needs regarding step resistance values and current ratings for each step. The boxes with open execution can also be tailor made to suit specific requirements. These can also be supplied as exact replacement of Russian type бФ-IT.

TECHNICAL DATA

- Ambient temperature up to 50°C.
- Relative humidity up to 100 %. However, max. ambient temp. and max. relative humidity should not occur simultaneously.
- Reference standard IPSS-1-10-002-82.
- Rated voltage 500 V AC or DC.

INFORMATION REQUIRED

The following data is required for design of resistance boxes.

For all types:

- Motor Rating : Output (KW), Speed, supply Voltage and Frequency.
- Rotor Data Open Circuit : Rotor Voltage, full load Rotor current for slipring machines
- Ambient temperature if it exceeds 50°C and temperature rise limits if any are applicable.
- Type : Open or Closed

In addition, for various duty conditions, the following specific data have to be furnished.

A For Starting Duty:

- Starting torque required, normally expressed as a percentage of full load torque.
- Duty cycle-either as number of starts per hour and time ON and time OFF or as %CDF.
- Number of steps in case of balanced symmetrical switching by contractor control. Switching sequence diagram is to be furnished if switching is carried out by drum controller or manual cam controller.

B For Regulating duty :

- Starting torque required.
- Steps of speed reduction required usually expressed as a % of rated speed or motor rpm.
- Torque or HP output required at motor shaft at each step or reduced speed.

OPTIONAL EXTRAS

- Degree of protection other than IP-23 for enclosed type of boxes.
- Any special dimension of open or enclosed type of Resistance boxes.
- Draw out type of resistance boxes for mounting on racks.
- Suitability for higher Voltage.
- Suitability for higher ambient temperature.

ORDERING INFORMATION

- Specify type No.
- Information required as indicated above.
- Optional extras if any.



Symbol Of Reliability

TABLE – 1 Specification of FGR – 1211 Standardised open type resistance boxes.

Resistance Box. Cat. No.	Continuous Current 'A'	Total resistance of the box in ohms	Step Resistance Value							No. of Terminals	No. of Elements in Box.
			1 – 2	2 – 3	3 – 4	4 – 5	5 – 6	6 – 7	7 – 8		
FGR-1211-01A	195	0.1	0.0209	0.0191	0.0191	0.0209	0.02			6	5
FGR-1211-01B	173	0.1	0.0209	0.0191	0.0191	0.0209	0.02			6	5
FGR-1211-02A	165	0.1275	0.0245	0.0265	0.0265	0.0245	0.0255			6	5
FGR-1211-02B	153	0.131	0.0253	0.0271	0.0271	0.0253	0.0262			6	5
FGR-1211-03A	138	0.1925	0.037	0.04	0.04	0.037	0.0385			6	5
FGR-1211-03B	125	0.2	0.0385	0.0415	0.0415	0.0385	0.04			6	5
FGR-1211-04A	116	0.3	0.059	0.061	0.061	0.059	0.06			6	5
FGR-1211-04B	100	0.3	0.059	0.061	0.061	0.059	0.06			6	5
FGR-1211-05A	97	0.4	0.08	0.08	0.08	0.08	0.08			6	5
FGR-1211-05B	86	0.4	0.08	0.08	0.08	0.08	0.08			6	5
FGR-1211-06A	83	0.51	0.102	0.102	0.102	0.102	0.102			6	5
FGR-1211-06B	77	0.525	0.105	0.105	0.105	0.105	0.105			6	5
FGR-1211-07A	69	0.77	0.154	0.154	0.154	0.154	0.154			6	5
FGR-1211-07B	62	0.8	0.16	0.16	0.16	0.16	0.16			6	5
FGR-1211-08A	58	1.2	0.24	0.24	0.24	0.24	0.24			6	5
FGR-1211-08B	50	1.2	0.24	0.24	0.24	0.24	0.24			6	5
FGR-1211-09A	49	1.6	0.32	0.32	0.32	0.32	0.32			6	5
FGR-1211-09B	43	1.6	0.32	0.32	0.32	0.32	0.32			6	5
FGR-1211-10A	42	2.12	0.425	0.425	0.425	0.425	0.425			6	5
FGR-1211-10B	37.6	2.12	0.425	0.425	0.425	0.425	0.425			6	5
FGR-1211-11A	36	3.1	0.459	0.477	0.453	0.471	0.471	0.465	0.304	8	5
FGR-1211-11B	31	3.1	0.459	0.477	0.453	0.471	0.471	0.465	0.304	8	5
FGR-1211-12A	30	4.2	0.623	0.647	0.613	0.637	0.637	0.633	0.41	8	5
FGR-1211-12B	26.7	4.35	0.644	0.669	0.637	0.66	0.66	0.653	0.427	8	5
FGR-1211-13A	26	5.6	0.803	0.889	0.841	0.827	0.827	0.865	0.548	8	5
FGR-1211-13B	23	5.6	0.803	0.889	0.841	0.827	0.827	0.865	0.548	8	5
FGR-1211-14A	22	7.1	1.05	1.09	1.04	1.08	1.08	1.06	0.7	8	5
FGR-1211-14B	20.5	7.25	1.076	1.111	1.063	1.1	1.1	1.087	0.713	8	5

Note : The above resistance boxes can be supplied to exactly replace USSR type HØ-1T, ЯС-4 or 4T.

TABLE – 2 Specifications of FGR – 1111 Standardised open type resistance boxes.

Resistance Box. Cat. No.	Continuous Current	Total Resistance (Ohms)	Resistance Box. Cat. No.	Continuous Current	Total Resistance (Ohms)
FGR-1111-01	0.9	260X 11	FGR-1111-15	7.7	3.5 X 11
FGR-1111-02	1.0	188 X 11	FGR-1111-16	8.6	2.8 X 11
FGR-1111-03	1.2	140 X 11	FGR-1111-17	10.5	1.95 X 11
FGR-1111-04	1.5	96 X 11	FGR-1111-18	11.8	1.45 X 11
FGR-1111-05	1.7	68 X 11	FGR-1111-19	13.5	1.1 X 11
FGR-1111-06	2.1	48 X 11	FGR-1111-20	15.3	0.9 X 11
FGR-1111-07	2.3	37 X 11	FGR-1111-21	17.1	0.7 X 11
FGR-1111-08	2.7	27.6 X 11	FGR-1111-22	18.0	0.64 X 11
FGR-1111-09	3.1	21.6 X 11	FGR-1111-23	20.7	0.48 X 11
FGR-1111-10	3.4	18 X 11	FGR-1111-24	22.7	0.4 X 11
FGR-1111-11	4.2	12 X 11	FGR-1111-25	25.4	0.32 X 11
FGR-1111-12	5.1	8 X 11	FGR-1111-26	28.1	0.26 X 11
FGR-1111-13	5.9	5.8 X 11	FGR-1111-27	32.3	0.2 X 11
FGR-1111-14	6.8	4.4 X 11			

Note :

1. 260 X 11 denotes 11 tappings of 260 Ohms.
2. The above resistance can be supplied to exactly replace USSR type ЯС – 3T.

Product improvement is a continuous process at KAKKU. Hence data given in this catalogue is subject to revision without notice.



Symbol Of Reliability

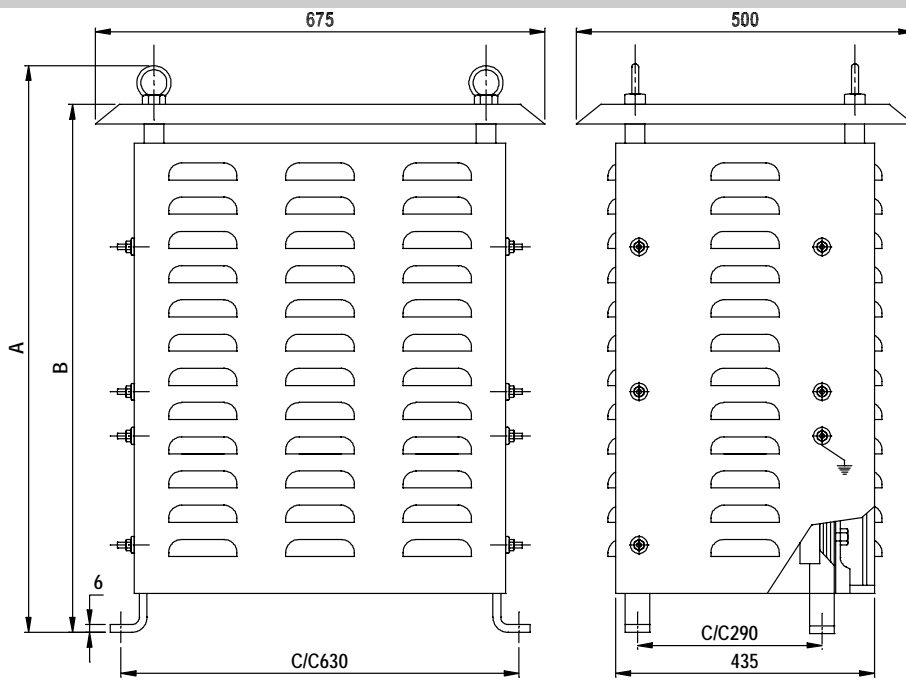

FIGURE - 1

RESISTANCE BOX

Type	A	B
FGR 1041	485	430
FGR 1042	685	630
FGR 1043	885	830
FGR 1044	1085	1030
FGR 1045	1285	1230
FGR 1046	1485	1430

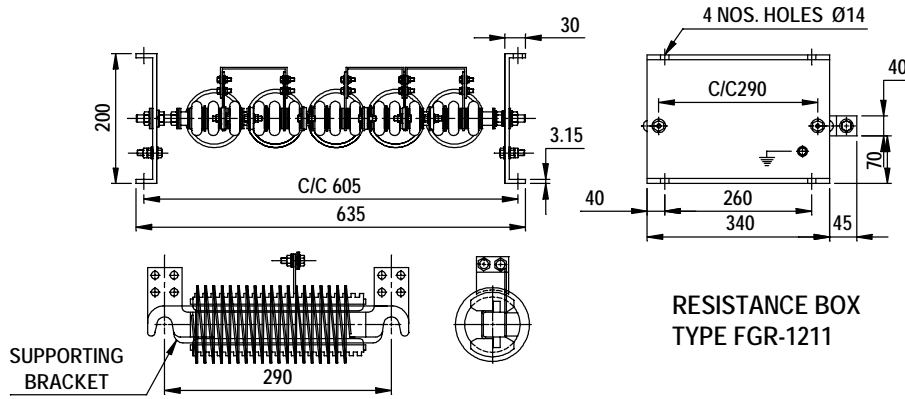

FIGURE - 2

RESISTANCE BOX
TYPE FGR-1211

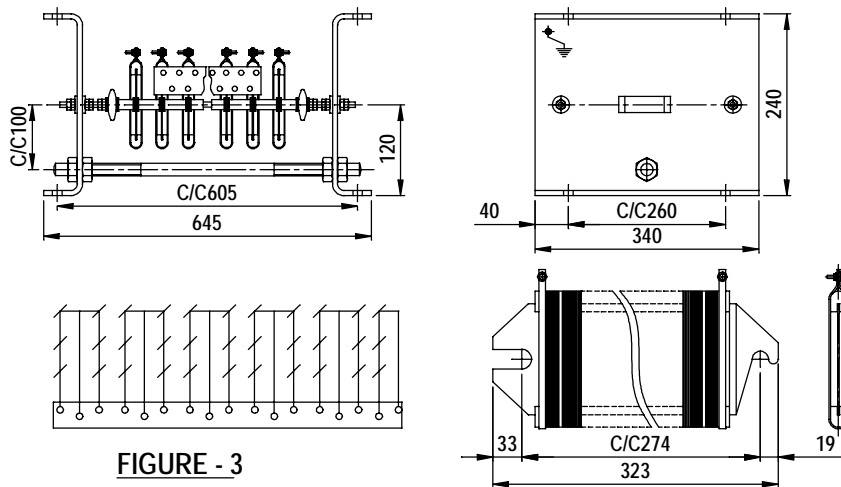

FIGURE - 3

RESISTANCE BOX
TYPE FGR-1111



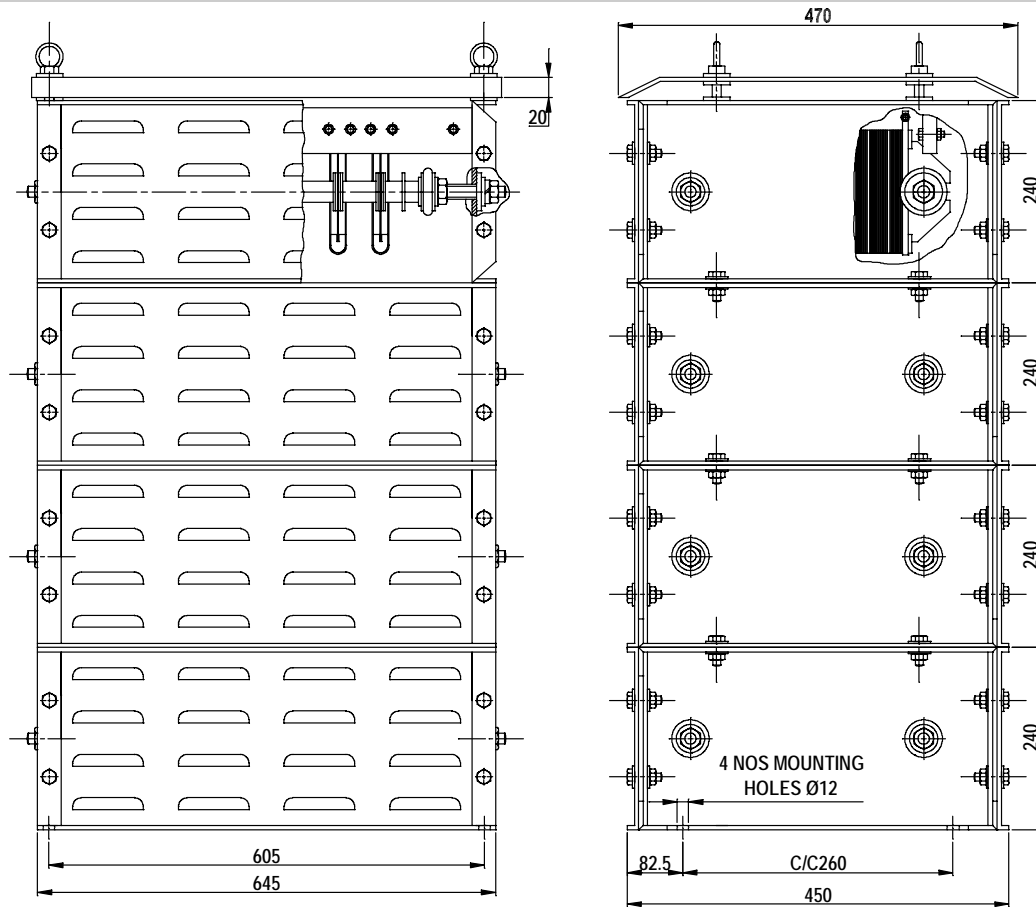

FIGURE - 4

RESISTANCE BOX

Type	A	High
FGR - 1131	260	1
FGR - 1132	500	2
FGR - 1133	740	3
FGR - 1134	980	4

